

# CHEMCHAMP

## MANUAL



## MODEL A18

### SOLVENT RECOVERY SYSTEMS (EXPLOSION PROOF UNITS)

FOR PROPER AND SAFE USE OF THIS CHEMCHAMP EQUIPMENT, PLEASE FOLLOW THIS DOCUMENT AND LOCAL AUTHORITY.

KEEP THIS DOCUMENT FOR FUTURE REFERENCE.

## TECHNICAL DATA:

MODEL:	CHEMCHAMP A18
CLASSIFICATION:	CLASS 1, DIVISION 1, GROUPS C, D, E, F, G
ELECTRICAL PROTECTION:	INTRINSIC PROTECTION & EXPLOSION PROOF ENCLOSURES
FUSE PROTECTION:	30 AMP DELAYED ACTION
VOLTAGE:	240 VAC, SINGLE PHASE, 50 or 60 Hz
AMPERAGE:	20 AMP
POWER:	4.2 kW
CAPACITY:	18 US GALLONS (68.14 litres)
OPERATING TEMPERATURE:	53.6 to 379.4 FAHRENHEIT (12° CELSIUS TO 193° CELSIUS)
SAFETY THERMOSTATS:	ELEMENT: 395 Fahrenheit (ELEMENT: 202° CELSIUS)
MATERIAL (DISTILLATION CHAMBER):	STAINLESS STEEL
PATENT PENDING PROCESS:	1) VAPOR MANAGEMENT SYSTEM. 2) PROCESS CONTROL METHOD. 3) ANTI-PRESSURE SYSTEM. 4) DIRECT CONDENSATION METHOD.
DIMENSIONS:	LENGTH: 82 Inches (208 cm) HEIGHT: 67 Inches (170 cm) WIDTH: 30.5 Inches (77.5 cm)
DISTILLATION TIME:	6 - 10 HOURS
COOL DOWN TIME:	9-12 HOURS.

## **INTRODUCTION:**

In dealing with liquid hazardous waste companies have had to pay a costly rate for pick-up and repurchase of new chemicals for their process. This recycler reduces these costs. The means of accomplishing the above is through a process known as distillation. Each group of chemicals has a vapor temperature, which we utilize to separate from contaminants. This unit is explosion proof, which means it can be used for flammable and non-flammable solvents ranging from acetone to water.

## **SAFETY FEATURES:**

The unit comes equipped with the following patent pending safety features:

- A) Automated temperature and time setting. The unit will automatically set its own time and temperature in accordance with the requirements of the particular solvent or solvents poured into its distillation chamber for recycling. The result being the operator only needs to pour the solvent in and press "START".
- B) Oil immersion element.
- C) Element control and safety probes.
- D) Oil maintenance timer and indicator. The unit will automatically indicate when oil requires to be changed. If oil is not changed within a safe time period, the unit will automatically shut down indicating the word "OIL" on its display panel until oil is changed. This ensures proper and safe operation of the unit for years to come.
- E) Intrinsically safe controls.
- F) Self-cooling condensation drum.
- G) A superior vapor management system. The vapor management system limits VOC emissions during distillation, resulting in a safe healthy working environment with an ultimate recovery of solvent.
- H) "OFF" button for manual shut off at any time. If the unit is in cycle and the stop button is pressed the unit will shut off and automatically go into cool down mode with yellow light flashing and digital displaying temperature until the unit reaches 134.6° Fahrenheit (57° Celsius). The yellow light and display will turn off and green light will come on indicating unit is safe to open and re-start cycle.
- I) Automatic shut off when cycle is complete.
- J) Unit operates at zero pressure. Cover will release at 0,15 Bar (2 PSI).
- L) Temperature Probes check each other 256 times per second to ensure the other is working within 50 degrees Fahrenheit (10 degrees Celsius) of itself.
- M) Temperature Probes are linked to an Analog circuit as well as the microprocessor. In the event the processor malfunctions, the Analog circuit will turn the unit off at 395 degrees Fahrenheit (202 degrees Celsius) until the unit cools.
- N) Fuse Protection.
- O) Overfill protection. Float sensor automatically shuts elements down in the event that the collection drum becomes overfull and displays "Er10".

## **PLEASE NOTE THE FOLLOWING:**

1. This unit is designed to distill solvent with a boiling temperature less than 356 degrees Fahrenheit (180 degrees Celsius).
2. This unit should never be used to distill any chemical with an auto-ignition temperature below 437 degrees Fahrenheit (225 degrees Celsius). Before initiating the distillation process always consult the appropriate chemical data sheet.
3. The distilled solvent must be collected in the drum provided with unit, caution should be taken that solvent not be accidentally spilled.
4. If distilling water, system must be flushed of all solvents prior to operation.
5. NITROCELLULOSE must **never** be distilled in this unit, as this may cause conditions of danger.
6. Residues must be disposed of in accordance to local laws.
7. When cleaning residues from unit use only non-sparking tools.
8. Opening cover before allowed time will cause gasket swelling & dislocation.
9. Operators should wear anti-static clothing.
10. Operating staff must be fully educated on the safe and correct use of unit and protection devises.
11. Gasket of the lid is to be replaced every 2 years.
12. This unit is not equipped with a plug, the proper connection must be implemented in accordance with the local authority.
13. Unit must be operated with the provided collection drum connected to the condensation drum. (see figure 1)

**FAILURE TO FOLLOW ANY OF THE ABOVE COULD CAUSE PERSONAL INJURY AND PROPERTY DAMAGE.**

## INSTALLATION OF UNIT:



Figure 1

1. **LOCATION:** Caution- To reduce the risk of fire or explosion, install, operate, and maintain this equipment in accordance with this instruction manual. This unit is for use in 104°F (40°C) environment with no forced ventilation. Under these conditions, the unit shall be spaced a minimum 3 feet (0.914m) from potential sources of ignition such as electrical receptacles, switches, pilot lights, fixtures, contacts, and other similar equipment that can produce sparks. If the equipment is used in higher ambient temperatures, an increase in spacing to sources of ignition shall be considered. This unit has only been investigated for use with solvent with a maximum ignition temperature of 437°F (225°C).

This unit is designed for use in Class 1, Division 1. Note: This unit is not equipped with a plug, the proper connection must be implemented in accordance with the local authority.

2. **ELECTRICAL REQUIREMENTS:** The A18 unit is to be either plugged or wired into an electrical source with 200 – 250 volts and on a 25 amp circuit.
3. **OIL AIR RELEASE VALVE:** Open front door and replace oil cap marked with an “X” with oil cap found in distillation chamber. The oil cap in distillation chamber has a hole in center of cap.
4. **PREPARING THE CONDENSATION DRUM:** The condensation drum acts as the main means for condensing the distilled vapors. The condensation drum is shipped empty and must be filled with the intended solvent (the solvent that will be distilled in the unit)

prior to operation. Remove the 2" plug from the condensation drum fill hole. Pour 36 gallons of intended solvent into hole using a funnel (not provided). Unit can be over filled and then drained to the correct level by connecting the collection can and fully draining any excess. **Be sure to empty collection can prior to operating unit.**

5. **PREPARING CONDENSER COLUMN (MAGIC BOX) AND CONNECTING THE VENT:** The condenser column or magic box acts as a vent for the system and as a secondary condensing module. The condenser column is shipped empty and must be filled with tap water prior to operation. Rotate the column lid, pour water into container until water level is 1" below top of container. Replace lid and attach vent hose to vent mount on column (see figure 2). Attach other end of vent hose to a formidable vent away from any source of ignition.

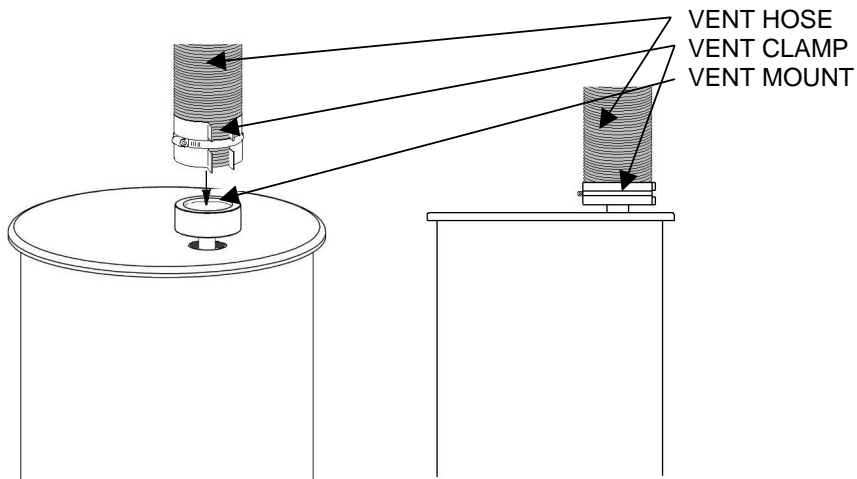

Figure 2

6. **ATTACHING COLLECTION DRUM:** The collection vessel is a fully mobile unit complete with its own pump and grounding attachment. The collection vessel must be connected to the condensation drum via the solvent line quick-connect and the grounding clamp attached to the condensation drum connector prior to each cycle (see figure 3).

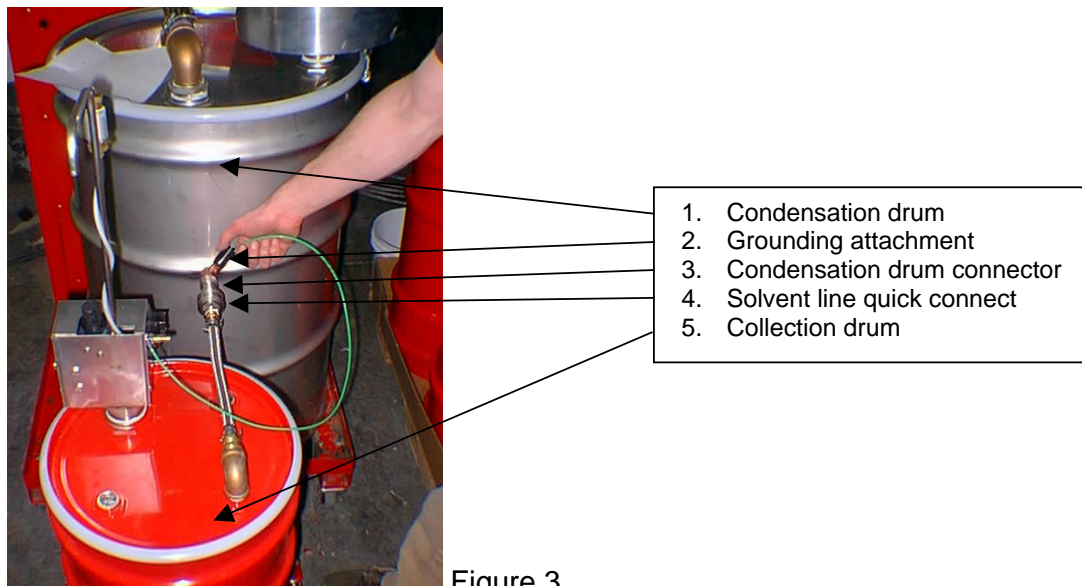

Figure 3

7. **GETTING READY:** Connect power. Press "START" button and green light will come on. The green light signifies the unit is ready to work and is safe to open.

## **INSTALLATION OF BAGS:**

1. Open cover.
2. Remove bag holder.
3. Open bag and place inside bag holder.
4. Fold top of bag over the top ring of bag holder.
5. Squeezing top ring, fit bag holder and bag into unit making sure bag is held open once installed.
6. Make sure bag is under the vapor manifold, and waste intake valve making sure they are not blocked or covered (see figure 4).

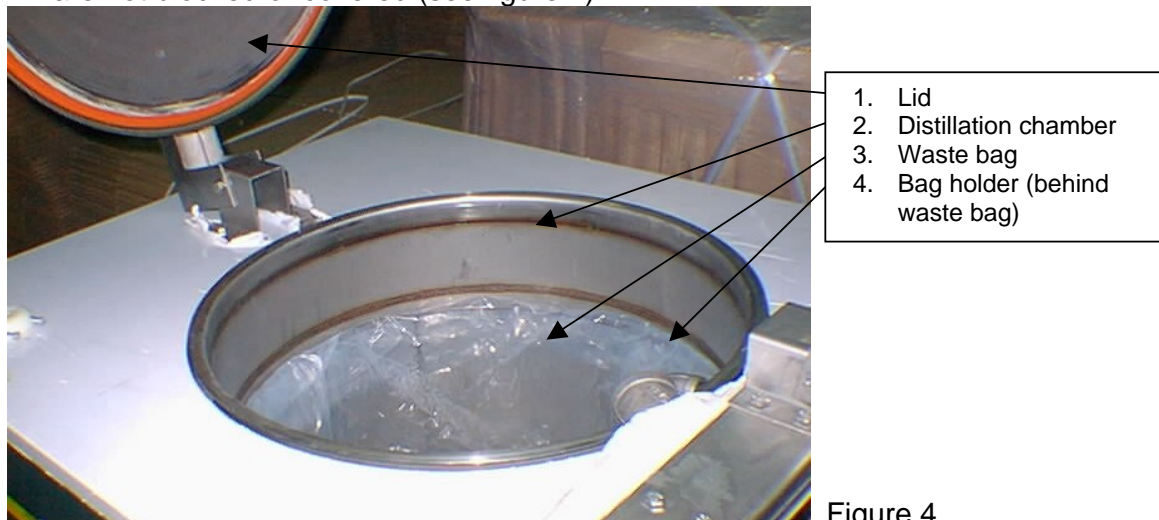

Figure 4

7. Pour solvent waste into receptacle bag. Maximum level is 1.5 Inches (3.8 cm) below top of bag holder. The unit is designed for a maximum volume of 18 US Gallons (68.14 litres).

Over filling will result in overflow into vapor manifold resulting in dirty recycled solvent. Over filling will also cause paint getting in behind the bag. This will make it difficult to remove the bag, as the paint will act as glue making the bag stick to the bottom. If sticking happens press "START" and let unit warm up for 5 minutes. Press "OFF" and gently pull bag out.

**We recommend the use of CHEMCHAMP BAGS; other types of bags may deteriorate during cycle and create a hard residue at the bottom of distillation chamber that will be difficult to remove.**

## **OPERATION OF UNIT:**

1. Connect power.
2. Press "START" button and green light will come on. The green light signifies the unit is ready to begin a new batch and is safe to open.
3. Open lid.
4. Remove bag holder.
5. Place new waste bag inside holder.
6. Fold overlap of bag over the top of the holder.
7. Place bag and holder inside distillation chamber.
8. Pour a maximum of 18 US Gallons (68.14 litres) of waste solvent into bag, making sure not to pour any liquid into outlet manifold or behind waste bag. The maximum level is 1.5 Inches (3.8 cm) below the top of the bag holder
9. Close lid and clamp the lid clamp down.
10. Ensure collection drum is empty and properly connected to the condensation drum (see figure 3).
11. Press "START", yellow light and digital display will come on. The display shows the temperature of the thermal oil.
12. Green light will stay on with yellow light until temperature of the thermic oil reaches 140 degrees Fahrenheit (60 degrees Celsius). At this point the green light will turn off. Unit will automatically set temperature and time in accordance to the solvent or solvents to be recycled.
13. Once distillation is complete the unit will automatically shut off and the yellow light will begin flashing indicating the unit is "OFF" and is cooling down. The yellow light will flash until the unit has fully cooled. At this point the yellow light and the digital display will turn "OFF" and the unit is ready for the next cycle. The green light will come on once the unit is safe to open.
14. Open cover and remove bag residue. Place residue bag into proper collection drum.

\* Please note that by using bags in the distillation chamber, you eliminate the cleaning process.

\*\* Please use necessary safety precautions when following these steps.

\*\*\* Very Important: Eye wear, boots, gloves and masks should be worn at all times.

\*\*\*\*CAUTION: Unit surfaces will be hot when in use.

\*\*\*\*\*Cover should not be open unless green light is on.

\*\*\*\*\*Waste bag should be changed between each cycle.

## **OIL MAINTENANCE:**

### **OIL CHANGE**

The unit will automatically indicate it requires an oil change by flashing the word "OIL" on its display panel.

1. Disconnect power.
2. Open front door of unit.
3. Remove top and middle oil cap.

4. Place collection pan under Oil Drain.
5. Remove bottom oil cap & drain. **Caution:** Make sure when emptying oil that the unit is completely cooled
6. Replace bottom oil cap.
7. Hang a collection pail on middle oil nipple.
8. Using a flexible funnel, refill oil with ChemChamp Heating Oil through top oil nipple. Fill unit until oil begins to drain from middle oil nipple.
9. Allow excess to fully drain from middle oil nipple.
10. Replace middle and top oil caps, NOTE: the top oil cap has a hole in it.
11. Reconnect power.
12. Press the "START" button for 20 seconds. All lights will come on and the screen will display "Clr" and then "8888", indicating self-diagnostic and reset of unit is complete.
13. Disconnect power.
14. Reconnect power and you are ready to set the unit for solvent or water mode.

### **OIL TOP-UP**

1. Disconnect power.
2. Open front door of unit.
3. Remove top and middle oil cap.
4. Using a flexible funnel, refill oil with ChemChamp Heating Oil through top oil nipple. Fill unit until oil begins to drain from middle oil nipple.
5. Allow excess to fully drain from middle oil nipple.
6. Replace middle and top oil caps, NOTE: the top oil cap has a hole in it.
7. Reconnect power.

## **COLLECTION DRUM:**

The collection drum provided with unit is the only vessel to be used for collection of distilled solvent. This drum holds a maximum of 18 US Gallons (68.14 litres). It is fully mobile and has its own pump. The pump is pneumatically powered and is operated with a push button. The unit must be connected to an air supply of at least 80 psi for the pump to function properly. The collection drum comes equipped with a grounding clamp to connect the unit to a suitable ground whenever stationary.

The collection drum must be empty and connected to the condensation drum via the solvent line quick connect for the duration of a distillation cycle. The collection drum must be attached to a suitable ground during a cycle. The condensation drum connector is a suitable ground.

## **TROUBLE SHOOTING:**

<u><b>Problem</b></u>	<u><b>Reason</b></u>	<u><b>Solution</b></u>
Bag hard to pull out.	- Dirty Inner Bucket.	- Turn machine on until it reaches 131 degrees Fahrenheit (55 degrees Celsius), remove bag and clean.
Machine will not come on.	- Surge in power.	- Replace fuse or fuses in explosion proof box.
Dirty Distillate. Rust colored solvent.	- Dirty manifold. - Dirty collection drum. - Rusty drum.	- Clean manifold. - Replace or clean drum. - Replace collection drum.
Gasket swelling and dislocating.	- Lid was opened before unit finished its cool down mode.	- Replace gasket immediately.
Control panel error message.	- System failure.	- Take note of error message number i.e.) Er01. - See error code section on following page. - Contact ChemChamp.
Waste residues are becoming soupy	- Unit low on oil	- Top unit up with oil - See "OIL MAINTENANCE SECTION"
Unit smells during operation	- Increased vapor losses	- Add water to condensation column

## **ERROR MESSAGES**

### **CODE**

### **ERROR**

Er01	Probe 1 fault (Invalid temperature values). Room temperature is less than 50 Fahrenheit
Er02	Probe 2 value too different from probe 1.
Er03	Probe 1 value too different from probe 2.
Er04	Over temperature fault (Hardware overtemp trip).
Er05	Over temperature fault (From A/D read).
Er10	Condensation drum is overfull. Either the collection drum is full and needs to be emptied or the collection drum is not connected during cycle.